

BOT 2520



- (EN) Not suitable for children under 3 years old due to small parts. Choking hazards.
- (FR) Présence de petits éléments. Danger d'étouffement.
- (DE) Nicht geeignet für Kinder unter 3 Jahren. Kleinteile, Erstickengefahr.
- (ES) Contiene pequeños elementos; Peligro de atragantamiento.
- (IT) Presenza di piccoli elementi; Pericolo di soffocamento.
- (RU) Изделие содержит мелкие детали; Опасность удушья.

EN To avoid scratches on metal pipes, please assemble on soft surface.

DE Montieren Sie den Artikel auf weicher Unterlage, um Kratzer zu vermeiden.

IT Non esporre direttamente al sole in maniera che il bambino possa essere disturbato durante l'utilizzo, salita e discesa.

FR Pour éviter les rayures sur les tubes métalliques, merci de les assembler sur une surface adéquate

ES Para evitar marcas en las tuberías de metal, por favor ensamble sobre una superficie plana.

RU Во избежание царапин на металлических трубках, рекомендуется собирать на мягкой поверхности.

A

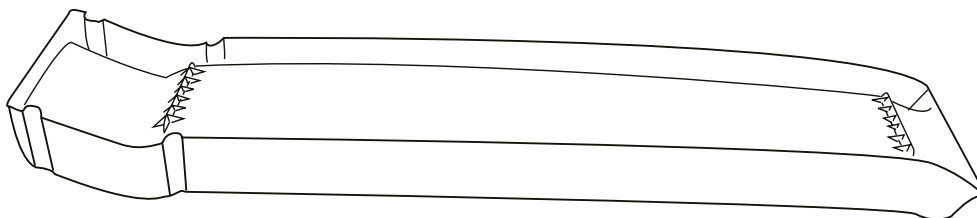

1-02-984

B X2

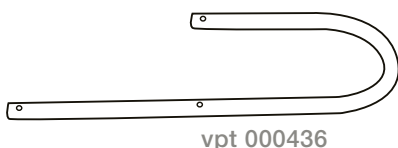

vpt 000436

C X2

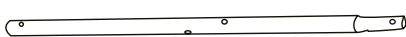

vpt 000437

D X2

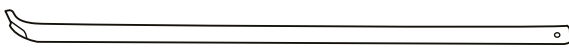

vpt 000438

E X1

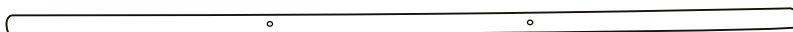

vpt 000439

F X3



2-04-984

G X2



3-11-982

J X2



vpt 000498

M X10

45 mm

vpt 000423

H X16



vpt 000421

K X2



3-01-984

N X8

40 mm

vpt 000424

I X2



2-11-982

L X2



1-11-982

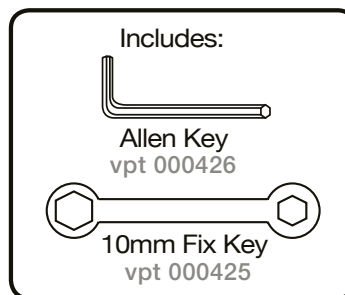

Spare parts not included



*Some tubes may contain another tube inside them. Please check all tubes before assembly.

1

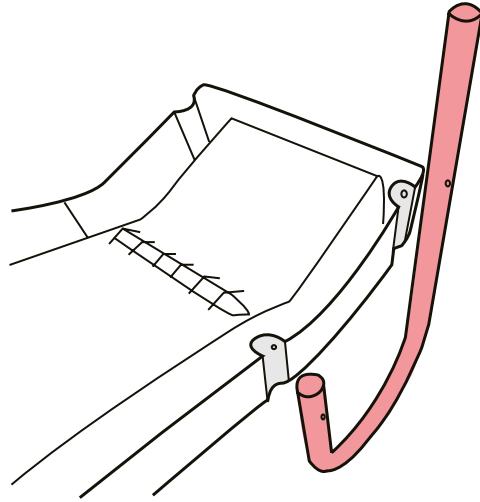

2

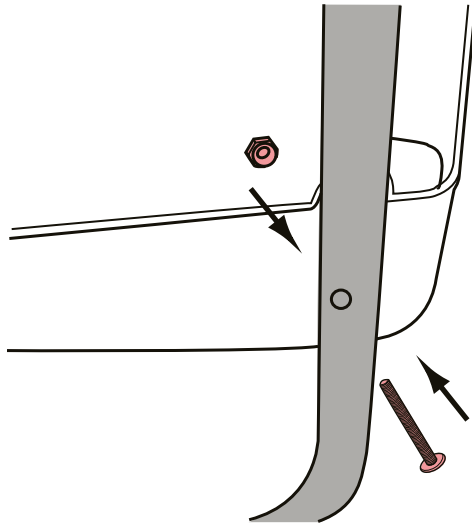
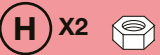

3

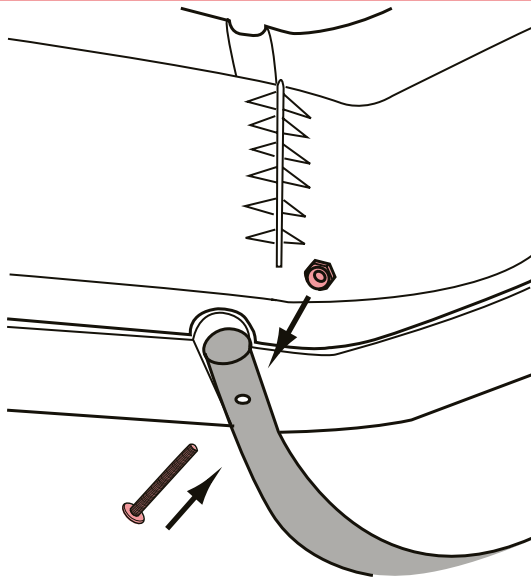
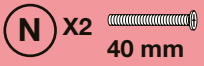
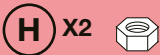

4

L

x2

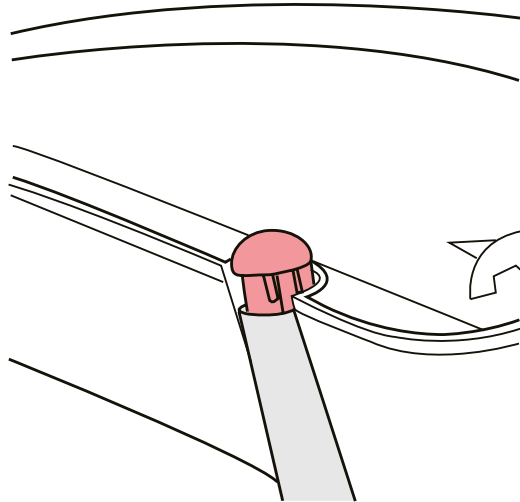

5

C

x2

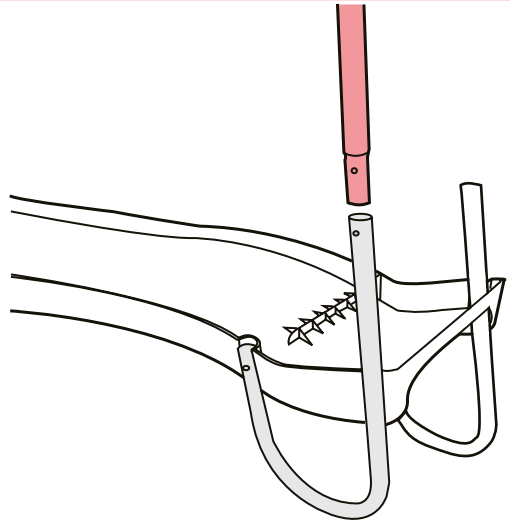

6

F

x1

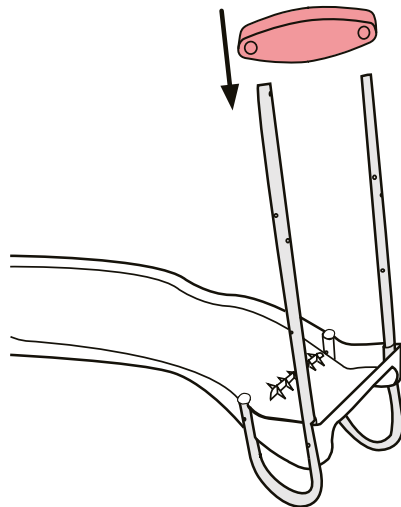

7

H X2 

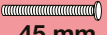
M X2  45 mm

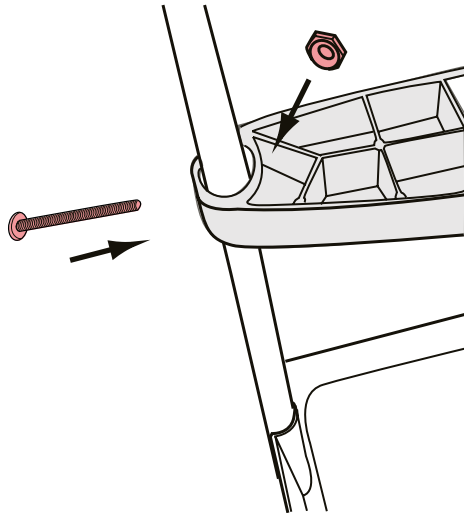

8

F X2 

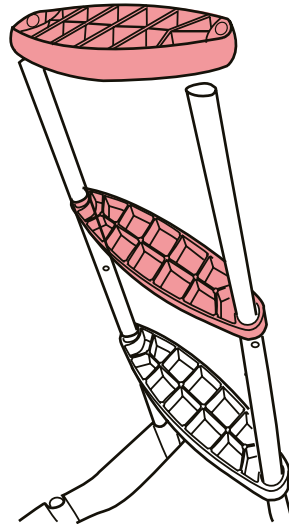

9

H X4 

M X4  45 mm

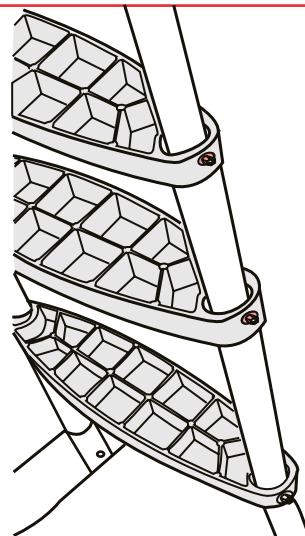

10

D X2

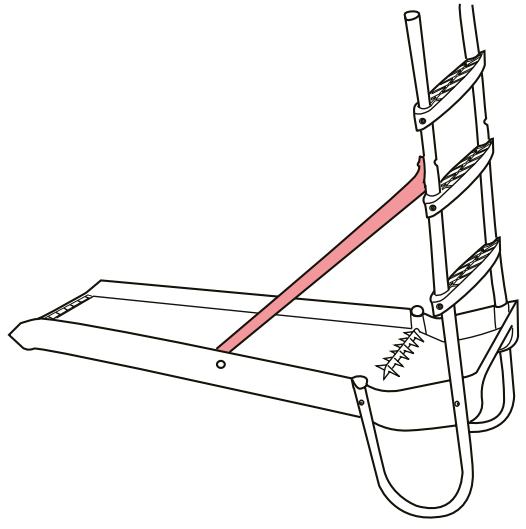

11

J X2



N X2
40 mm

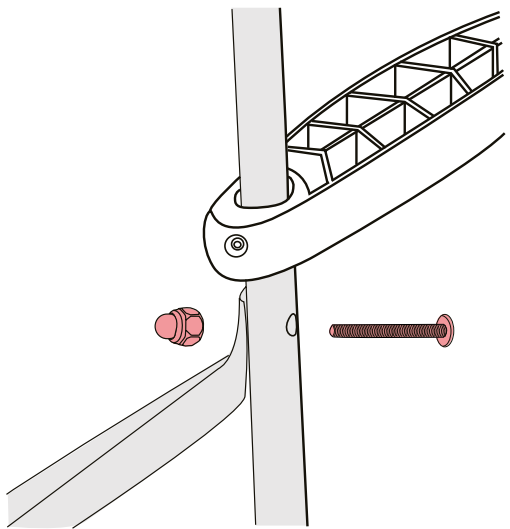

12

I X2



H X2



N X2
40 mm

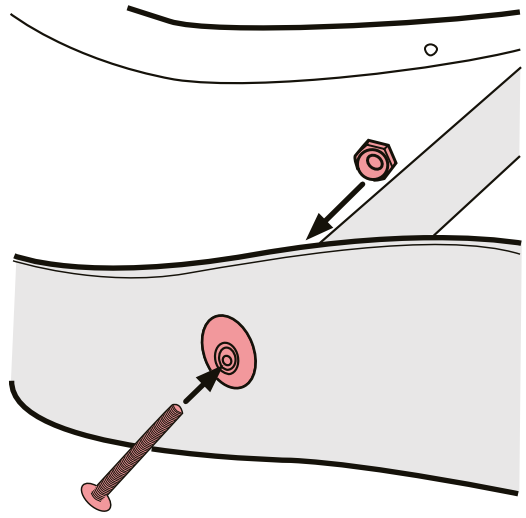

13

E X1



G X2

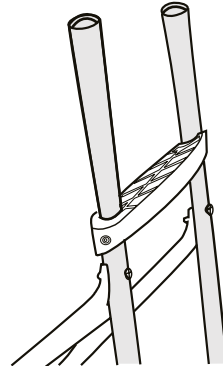

14

H X4



M X4

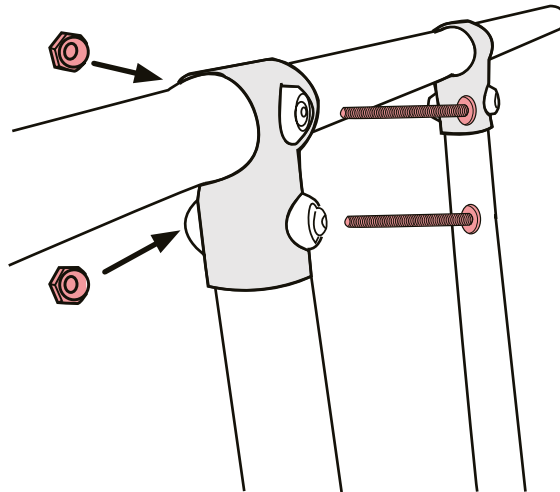
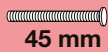

15

M X2

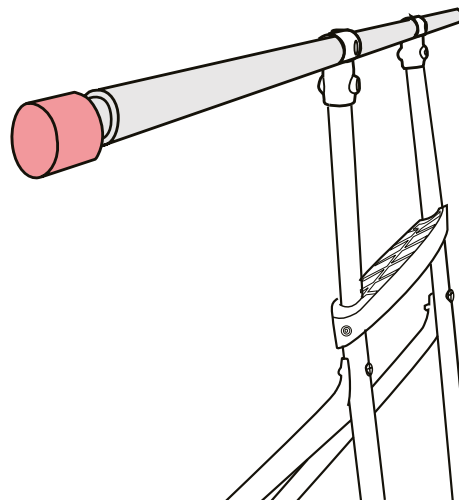

(EN)

WARNING! For domestic use only.
WARNING! Indoor / outdoor use.
WARNING! Max load: 50Kg.
WARNING! ⚠ Not suitable for children under 3 years. Small parts; Choking hazard.
Place the toy on a level surface at least 2m from any structure or obstruction, such as fence, garage, house, overhanging branches, laundry lines or electrical wires.
The toy shall not be installed over concrete, asphalt or any other hard surface.
Do not face slide-Chute directly towards to sun when in use.
Check regularly for continued security and for any evidence of deterioration or hazards.
Replace, if required, with suitable & new parts.
Failure to do so may result in an injury or fall.
Side bars are not for standing or climbing on.
Adult assembly required.
Adult supervision is required at all times.
Please keep this instruction sheet for future reference.
Remove all packing materials such as bags, bands & cartons.

(FR)

ATTENTION ! Utilisation en intérieur/extérieur.
ATTENTION ! Charge maxi. : 50 kg.
ATTENTION ! à usage domestique exclusivement.
ATTENTION ! ⚠ Présence de petits éléments. Danger d'étouffement
Placez le jouet sur une surface à niveau, à au moins 2 mètres d'une structure ou d'un obstacle quelconque (haie, garage, maison, branches inclinées, cordes à linge ou câbles électriques).
Il ne faut pas installer le jouet sur du béton, de l'asphalte, ou autre surface dure.
Ne pas orienter slide-Chute directement face au soleil pendant l'utilisation.
Vérifiez régulièrement les conditions de sécurité et soyez à l'affût de toute trace de détérioration ou de dangers.
Si nécessaire, procédez au remplacement d'éléments, avec les pièces neuves qui conviennent.
Les barres latérales ne sont pas faites pour se tenir debout ou pour monter dessus.
Si vous ne le faites pas, cela peut occasionner des blessures ou des chutes.
Le montage doit être réalisé par un adulte.
La supervision d'un adulte est requise en permanence.
Conservez ce feuillet d'instruction pour référence ultérieure.
Retirez tous les matériaux d'emballage (sacs, bandes et cartons).

(DE)

WAARSCHUWING! Alleen voor huishoudelijk gebruik.
WAARSCHUWING! Voor gebruik binnenshuis / buitenshuis.
WAARSCHUWING! Maximaal belasting: 50 kg.
WAARSCHUWING! ⚠ Nicht geeignet für Kinder unter 3 Jahren. Kleinteile, Erststückergefahr.
Plaats de glijbaan op een horizontaal oppervlak, minstens 2 m. van enige constructies of belemmeringen zoals een hek, garage, huis, overhangende takken, waslijnen of elektrische kabels.
De glijbaan mag niet op een harde ondergrond zoals beton of asfalt geïnstalleerd worden.
Keer tijdens gebruik de Glijbaan niet rechtstreeks richting de zon.
Controleer regelmatig op continue veiligheid en op tekens van beschadiging of gevaar.
Vervang zondig met geschikte en nieuwe onderdelen.
Zijbalken zijn niet bedoeld om op te staan of te klimmen.
Dit niet uitvoeren kan resulteren in verwonding of vallen.
De montage moet door een volwassene worden uitgevoerd.
Een volwassene moet ten alle tijden toezicht houden.
Bewaar deze instructies voor toekomstige referentie.
Verwijder alle verpakkingsmateriaal zoals tassen, elastiekjes & kartonnen.

(ES)

ADVERTENCIA! Solo para uso doméstico.
¡ADVERTENCIA! Uso bajo techo o al aire libre.
¡ADVERTENCIA! Carga máxima: 50 kg.
¡ADVERTENCIA! ⚠ Contiene pequeños elementos ; Peligro de atragantamiento
Colocar el tobogán sobre una superficie plana, al menos a una distancia de 2 metros de cualquier estructura u obstrucción, como por ejemplo, cercas, garajes, casas, ramas de árboles, tendederos de ropa o cables eléctricos.
No instalar el tobogán sobre hormigón, asfalto ni cualquier otra superficie dura.
Al utilizar el tobogán, no mirar directamente hacia el sol.
Revisar con regularidad para garantizar la seguridad y detectar señales de deterioro o peligros.
Si fuera necesario, cambiar por piezas adecuadas y nuevas.
De lo contrario, podría resultar en lesiones o caídas.
Las barras laterales no son para estar de pie en ellas o subirse a ellas.
El armado estará a cargo de un adulto.
Se requiere la supervisión de un adulto en todo momento.
Conservar esta hoja de instrucciones como referencia en el futuro.
Quitar todos los materiales de embalaje como bolsas, cajas de cartón y bandas.

(IT)

AVVERTENZA! Esclusivamente per uso domestico.
AVVERTENZA! Per uso in interni/esterni.
AVVERTENZA! Carico max: 50 Kg.WW
AVVERTENZA! ⚠ Presenza di piccoli elementi ; Pericolo di soffocamento
Posizionare lo scivolo su una superficie in piano ad almeno 2 m da ogni eventuale struttura o ostruzione, quali un recinto, un garage, una casa, rami sovrastanti, fili per il bucato o fili elettrici.
Non installare lo scivolo su calcestruzzo, asfalto o altra superficie dura.
Durante l'uso, non posizionare lo scivolo rivolto verso il sole.
Verificare regolarmente le condizioni di sicurezza e gli eventuali segni di deterioramento e di rischio.
Se necessario, sostituire le parti danneggiate con componenti nuovi e idonei.
In caso contrario potrebbero verificarsi lesioni o cadute.
Necessario il montaggio da parte di un adulto.
La supervisione di un adulto è costantemente necessaria.
Conservare questo foglietto illustrativo per eventuali riferimenti futuri.
Rimuovere tutti i materiali di imballaggio quali sacche, fascette e scatoloni.

(RU)

ВНИМАНИЕ! Только для бытового использования.
ВНИМАНИЕ! Для использования внутри помещения/снаружи.
ВНИМАНИЕ! Максимальная нагрузка: 50 кг.
ВНИМАНИЕ! ⚠ Изделие содержит мелкие детали ; Опасность удушья
Установите горку на ровной поверхности, по меньшей мере, в 2-х метрах от какого-либо строения или препятствия, например, забора, гаража, дома, нависающих ветвей, бельевой веревки или электрических проводов.
Не следует устанавливать горку на бетоне, на асфальте или любой другой твердой поверхности.
Во время использования не ставьте горку против солнечных лучей.
Регулярно проводите проверку в целях обеспечения безопасности и обнаружения признаков повреждения или износа.
При необходимости замените новыми подходящими деталями.
Запрещается вставать на боковые бортики или карабкаться по ним.
Несоблюдение этого требования может привести к травме или падению.
Сборка должна проводиться взрослым человеком.
Необходим постоянный присмотр взрослого человека.
Пожалуйста, сохраните эту инструкцию для использования в дальнейшем.
Удалите все упаковочные материалы, такие как пакеты, веревки и картон.

